

HY220

Εργαστήριο Ψηφιακών Κυκλωμάτων

Εαρινό Εξάμηνο
2023

Δυναμικές Μνήμες - DRAM

Βασικό Block Diagram Υποσυστημάτων Μνήμης

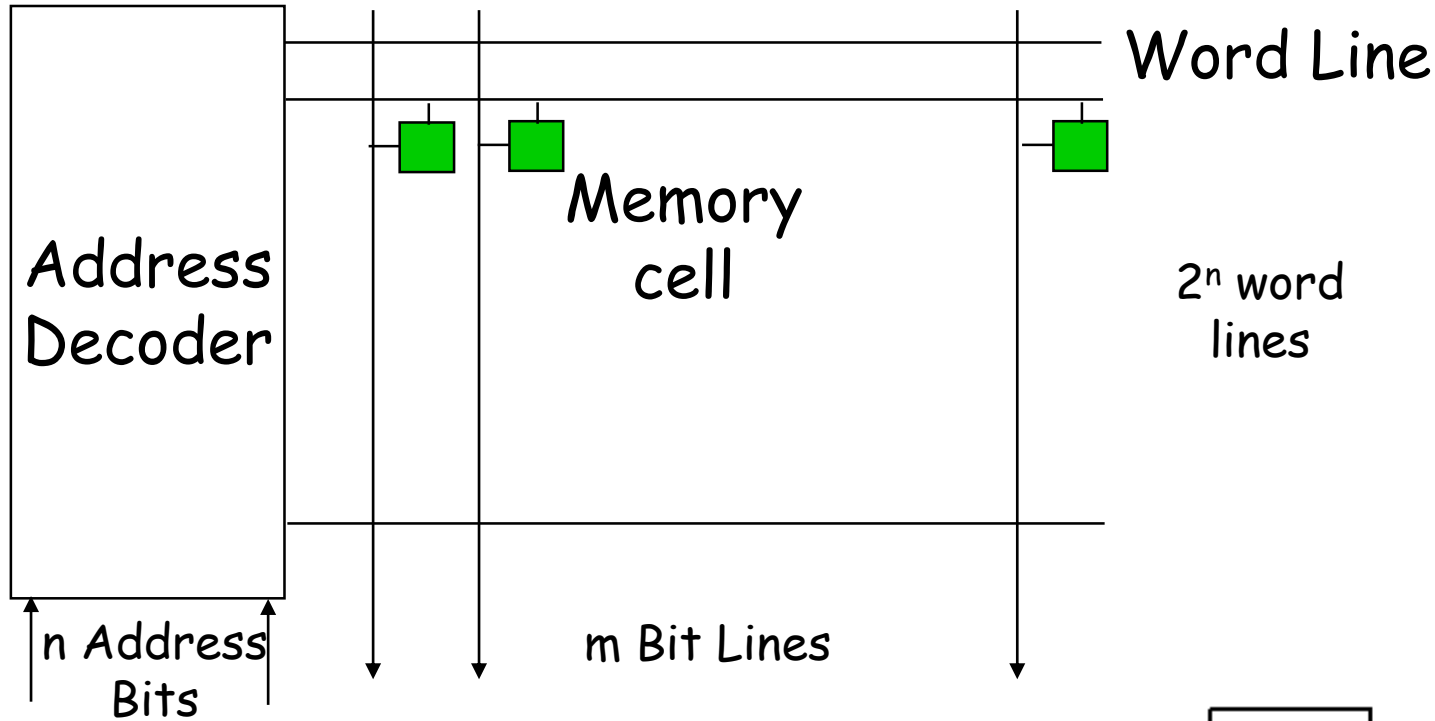

RAM/ROM ονοματολογία:

32 X 8, "32 by 8" => 32 8-bit words

1M X 1, "1 meg by 1" => 1M 1-bit words

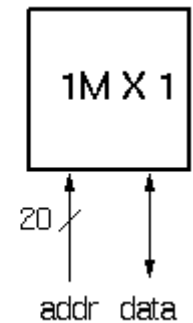
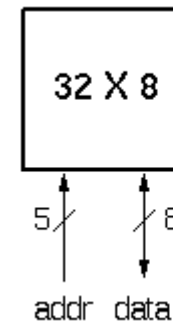

Κελί μνήμης με 1 transistor (DRAM)

- **Εγγραφή - Write:**
 1. Οδηγούμε την bit line
 2. Επιλέγουμε γραμμή (row select)
- **Ανάγνωση - Read:**
 1. Προφορτίζουμε (precharge) την bit line σε $V_{dd}/2$
 2. Επιλέγουμε γραμμή (row select)
 3. Το κελί και η bit line μοιράζονται τα φορτία (charge sharing)
 4. Sense στην bit line (sense amplifier)
Μπορεί να ανιχνεύει πολύ μικρές αλλαγές
 5. Write: επαναφέρουμε την τιμή
- **Ανανέωση - Refresh :**
 - Αρκεί ένα απλό read σε κάθε κελί

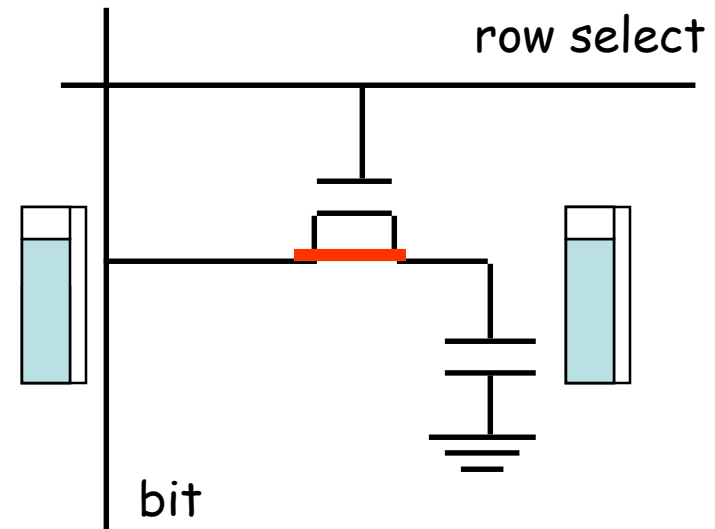

Κλασική Οργάνωση DRAM (τετραγωνική)

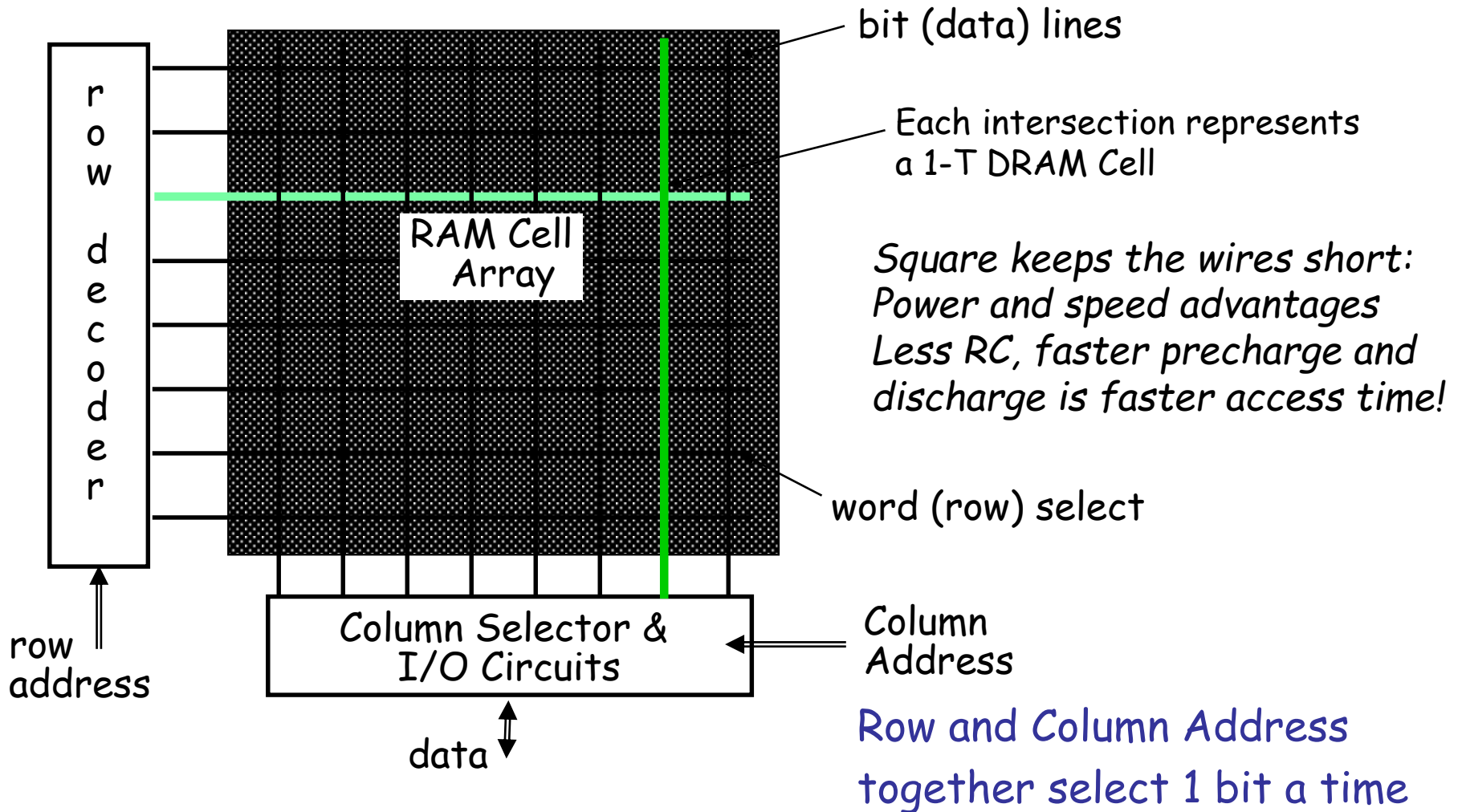

Λογική Οργάνωση DRAM (4 Mbit)

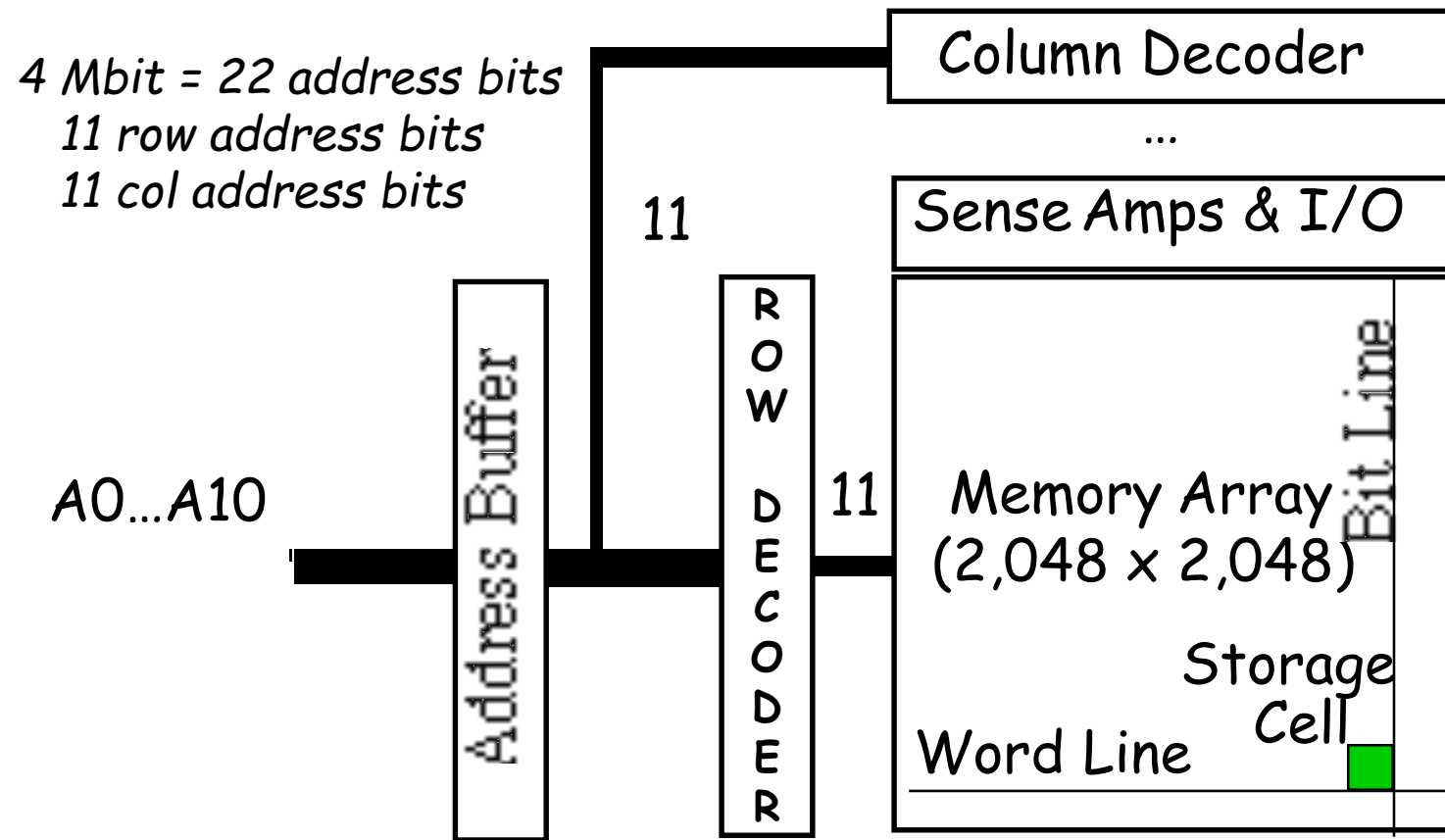

- Square root of bits per RAS/CAS
 - Row selects 1 row of 2048 bits from 2048 rows
 - Col selects 1 bit out of 2048 bits in such a row

Τα σήματα της DRAM

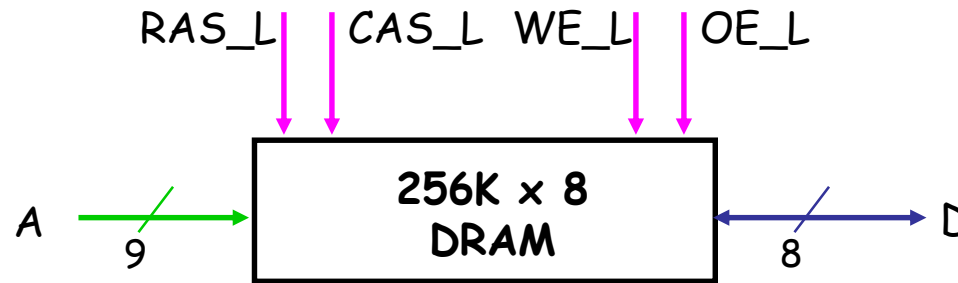

- Σήματα ελέγχου (RAS_L, CAS_L, WE_L, OE_L) όλα active low
- Κοινό bus δεδομένων D - εισόδου και εξόδου (Din & Dout):
 - WE_L ενεργοποιείται (Low), OE_L απενεργοποιείται (High)
 - D χρησιμοποιείται σαν είσοδος στην DRAM
 - WE_L απενεργοποιείται (High), OE_L ενεργοποιείται (Low)
 - D χρησιμοποιείται σαν έξοδος από την DRAM
- Οι διευθύνσεις γραμμής και στήλης μοιράζονται τα ίδια pins (A)
 - RAS_L ενεργοποιείται (low) -> A αποθηκεύεται σαν row address
 - CAS_L ενεργοποιείται (low) -> A αποθηκεύεται σαν column address
 - RAS/CAS edge-sensitive

Απλοποιημένο διάγραμμα χρονισμού DRAM

Read

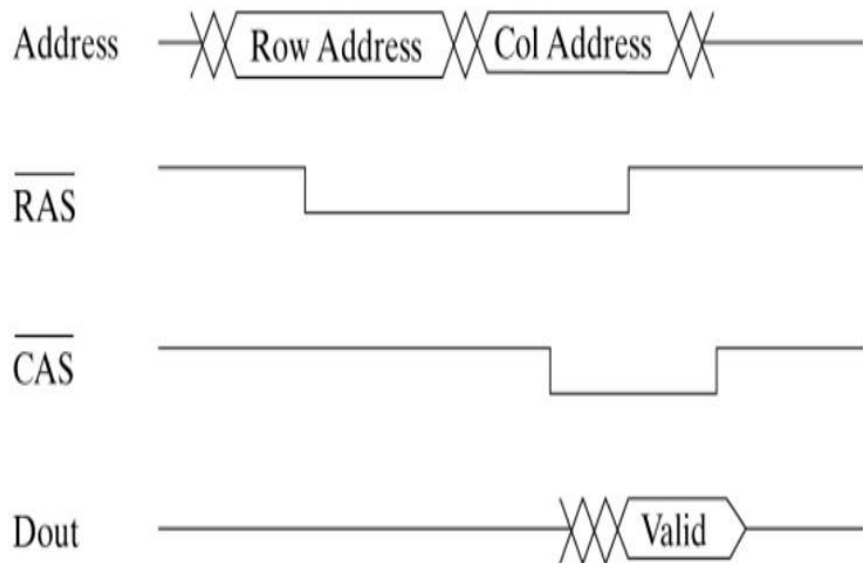

Write

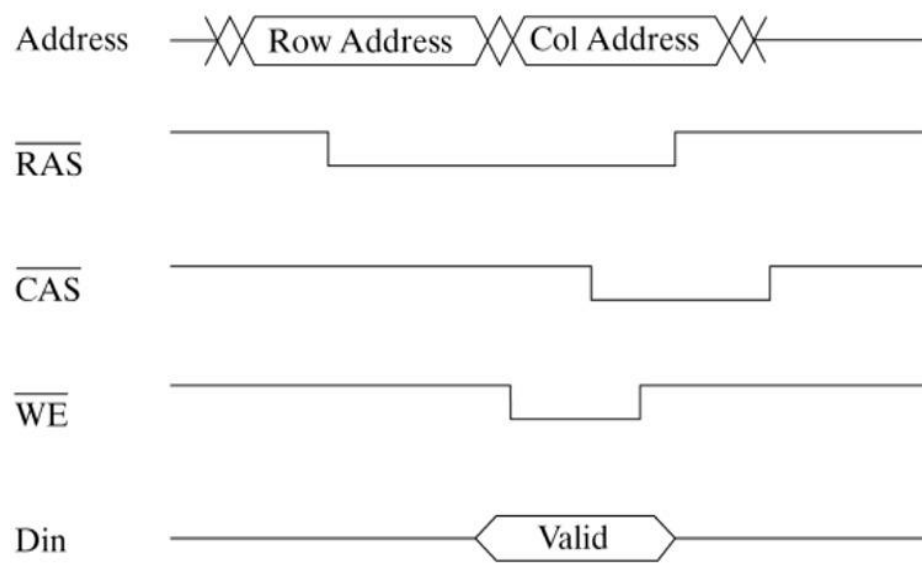

- Η διεύθυνση δίνεται σε 2 βήματα

Τυπικός χρονοισμός Ανάγνωσης DRAM

• Κάθε προσπέλαση DRAM ξεκινάει με:

- Ενεργοποίηση του RAS_L
- 2 τρόποι ανάγνωση: early or late

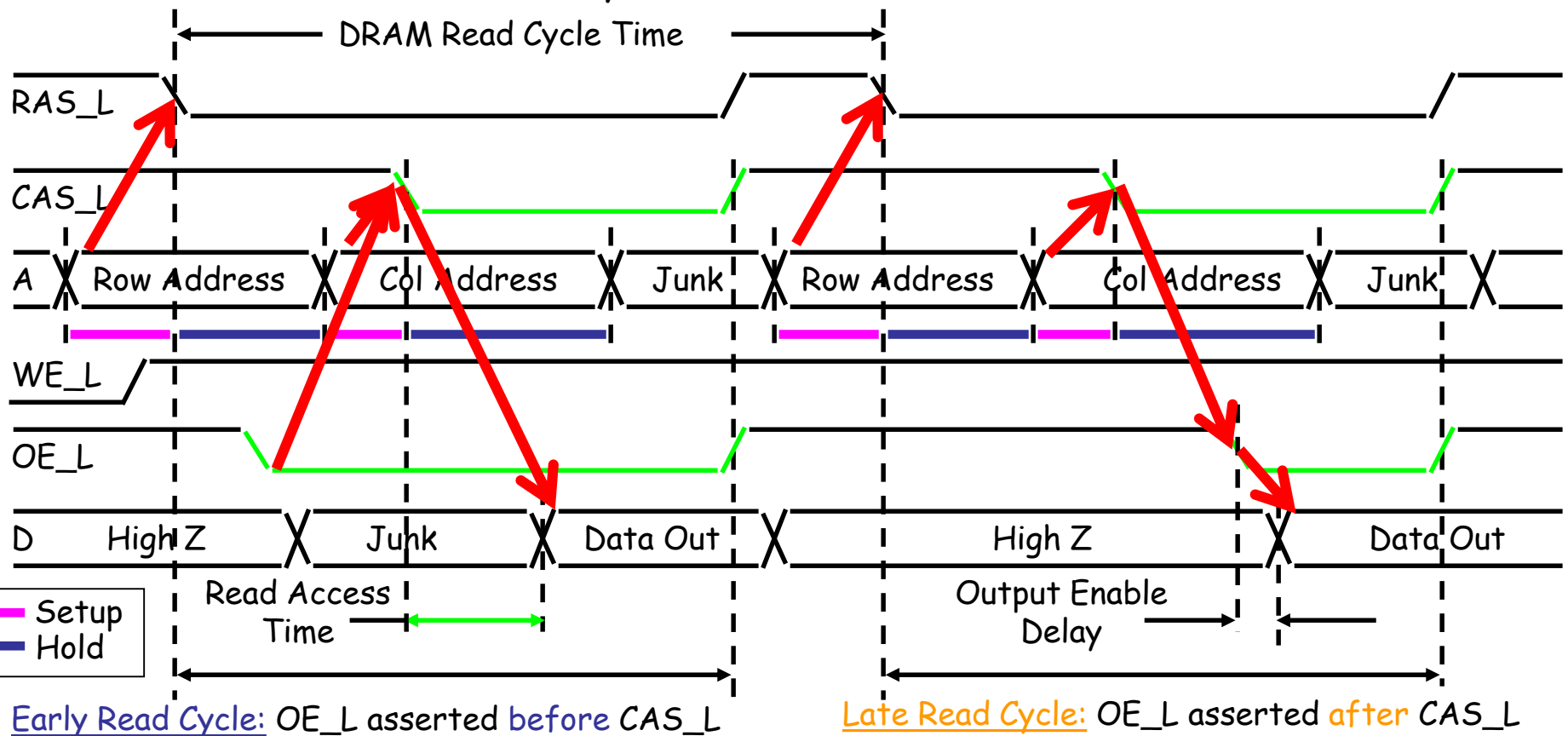
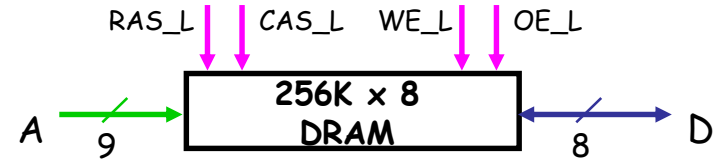

Τα βήματα για Early Read

- Assert Row Address
- Assert RAS_L
 - Start read cycle
 - Meet Row Addr setup time before RAS/hold time after RAS
- Assert OE_L
- Assert Col Address
- Assert CAS_L
 - Meet Col Addr setup time before CAS/hold time after CAS
- Valid Data Out after access time
- Disassert OE_L, CAS_L, RAS_L to end cycle

Τα βήματα για Late Read

- Assert Row Address
- Assert RAS_L
 - Start read cycle
 - Meet Row Addr setup time before RAS/hold time after RAS
- Assert Col Address
- Assert CAS_L
 - Meet Col Addr setup time before CAS/hold time after CAS
- Assert OE_L
- Valid Data Out after access time
- Disassert OE_L, CAS_L, RAS_L to end cycle

Τυπικός χρονοσμός Εγγραφής DRAM

- Κάθε προσπέλαση DRAM ξεκινάει με:
 - Ενεργοποίηση του RAS_L
 - 2 τρόποι εγγραφής: early or late

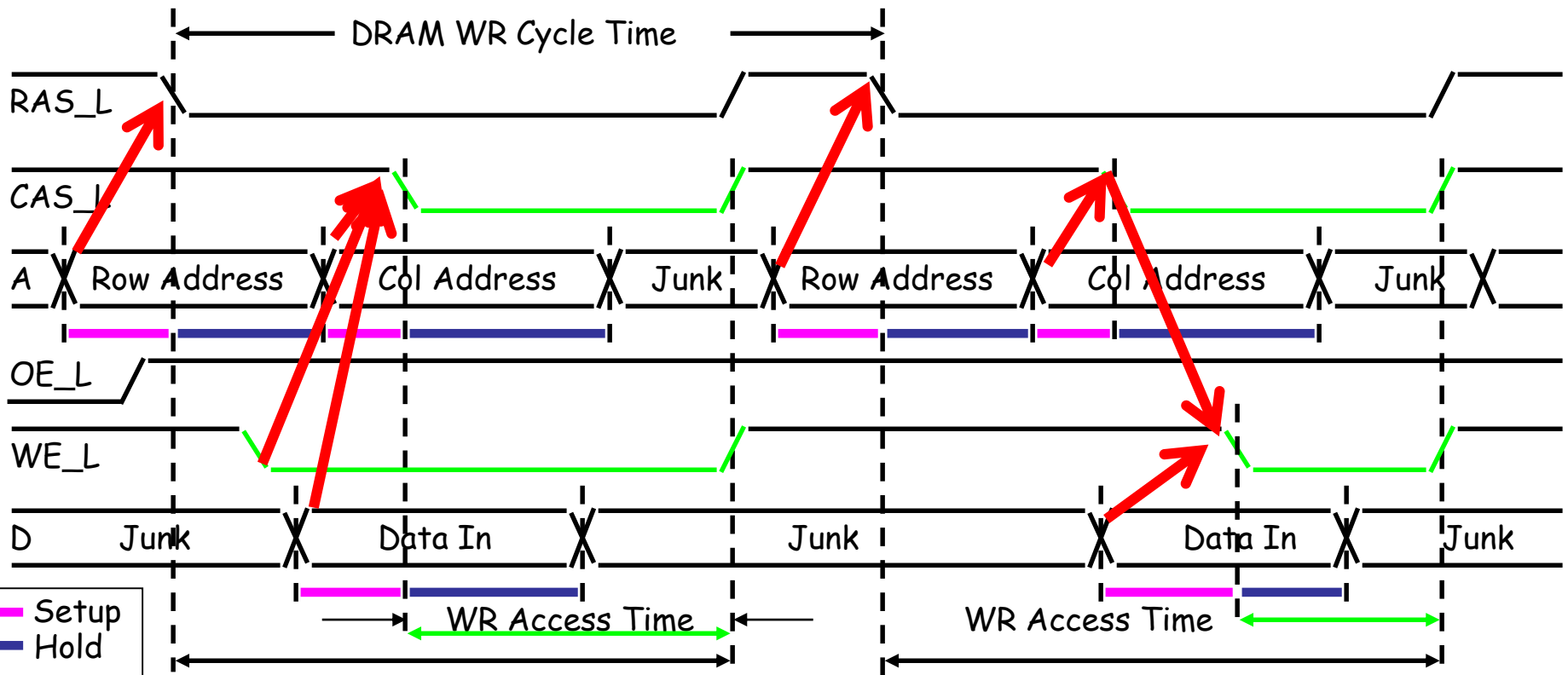
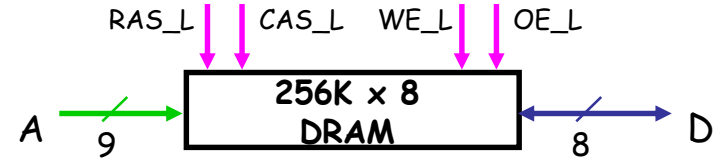

Early Wr Cycle: WE_L asserted before CAS_L

Late Wr Cycle: WE_L asserted after CAS_L

Key DRAM Timing Parameters

- t_{RAC} : minimum time from RAS line falling to the valid data output.
 - Quoted as the speed of a DRAM
 - A fast 4Mb DRAM $t_{RAC} = 60$ ns
- t_{RC} : minimum time from the start of one row access to the start of the next.
 - $t_{RC} = 110$ ns for a 4Mbit DRAM with a t_{RAC} of 60 ns
- t_{CAC} : minimum time from CAS line falling to valid data output.
 - 15 ns for a 4Mbit DRAM with a t_{RAC} of 60 ns
- t_{PC} : minimum time from the start of one column access to the start of the next.
 - 35 ns for a 4Mbit DRAM with a t_{RAC} of 60 ns

DRAM with Column buffer

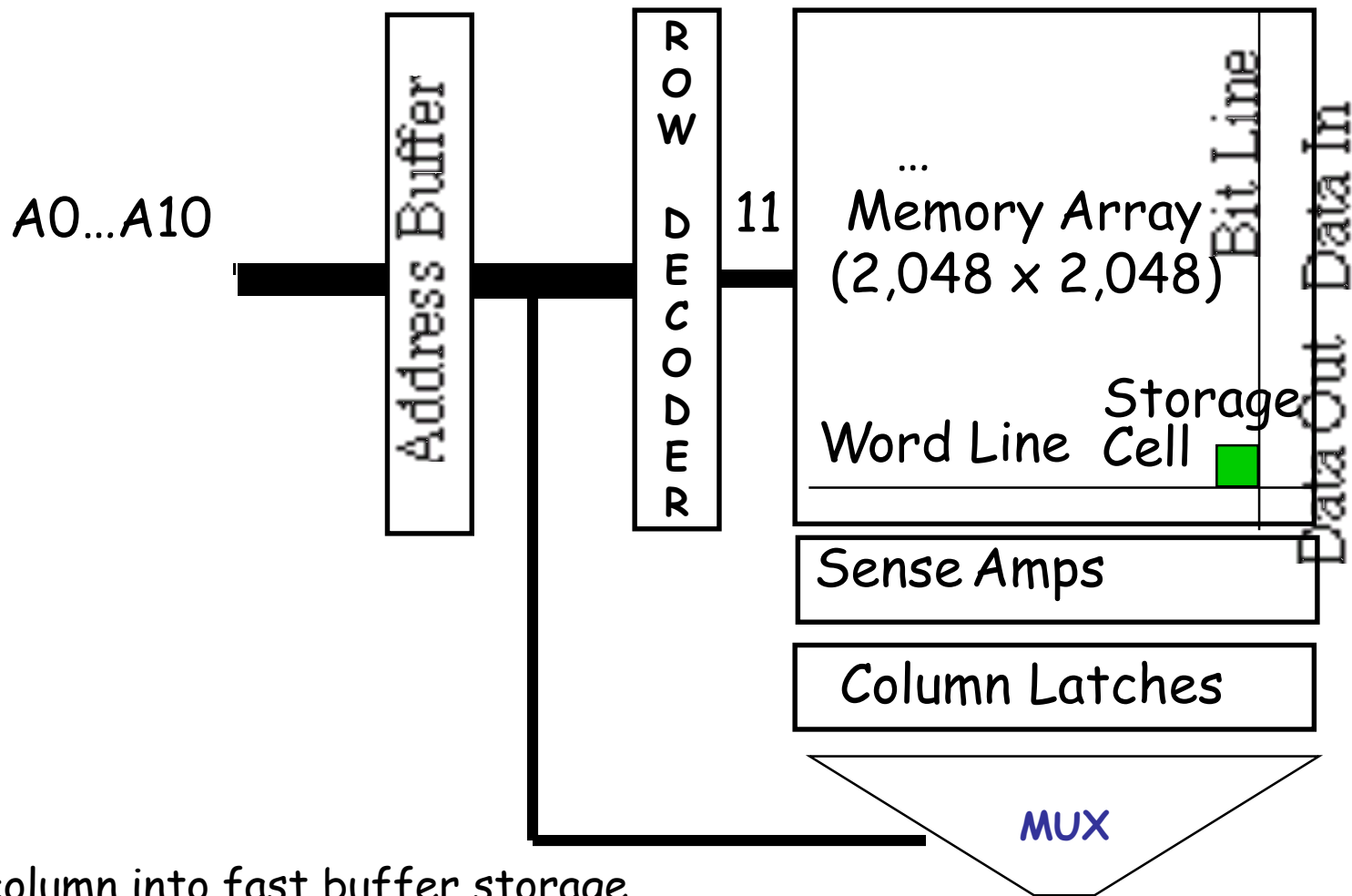

Pull column into fast buffer storage

Access sequence of bit from there

Optimized Access to Cols in Row

- Often want to access a sequence of bits
- Page mode
 - After RAS / CAS, can access additional bits in the row by changing column address and strobing CAS
- Static Column mode
 - Change column address (without repeated CAS) to get different bit
- Nibble mode
 - Pulsing CAS gives next bit mod 4
- Video ram
 - Serial access

256 Mbit SDRAM Addressing

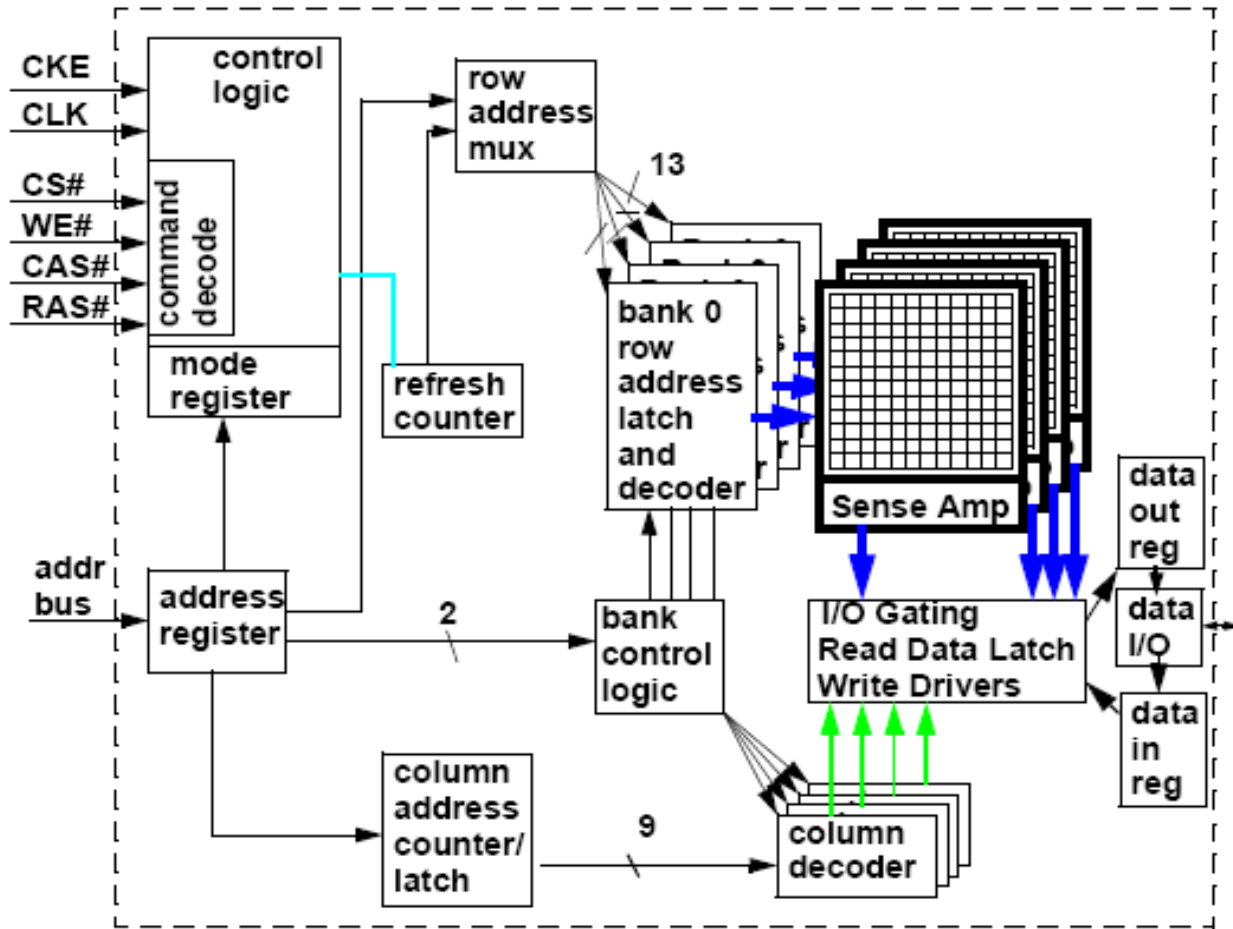

256 Mbit chip: 8192 rows, 512 columns, x16 data, 4 banks

Functional Block Diagram 8 Meg x 16 SDRAM

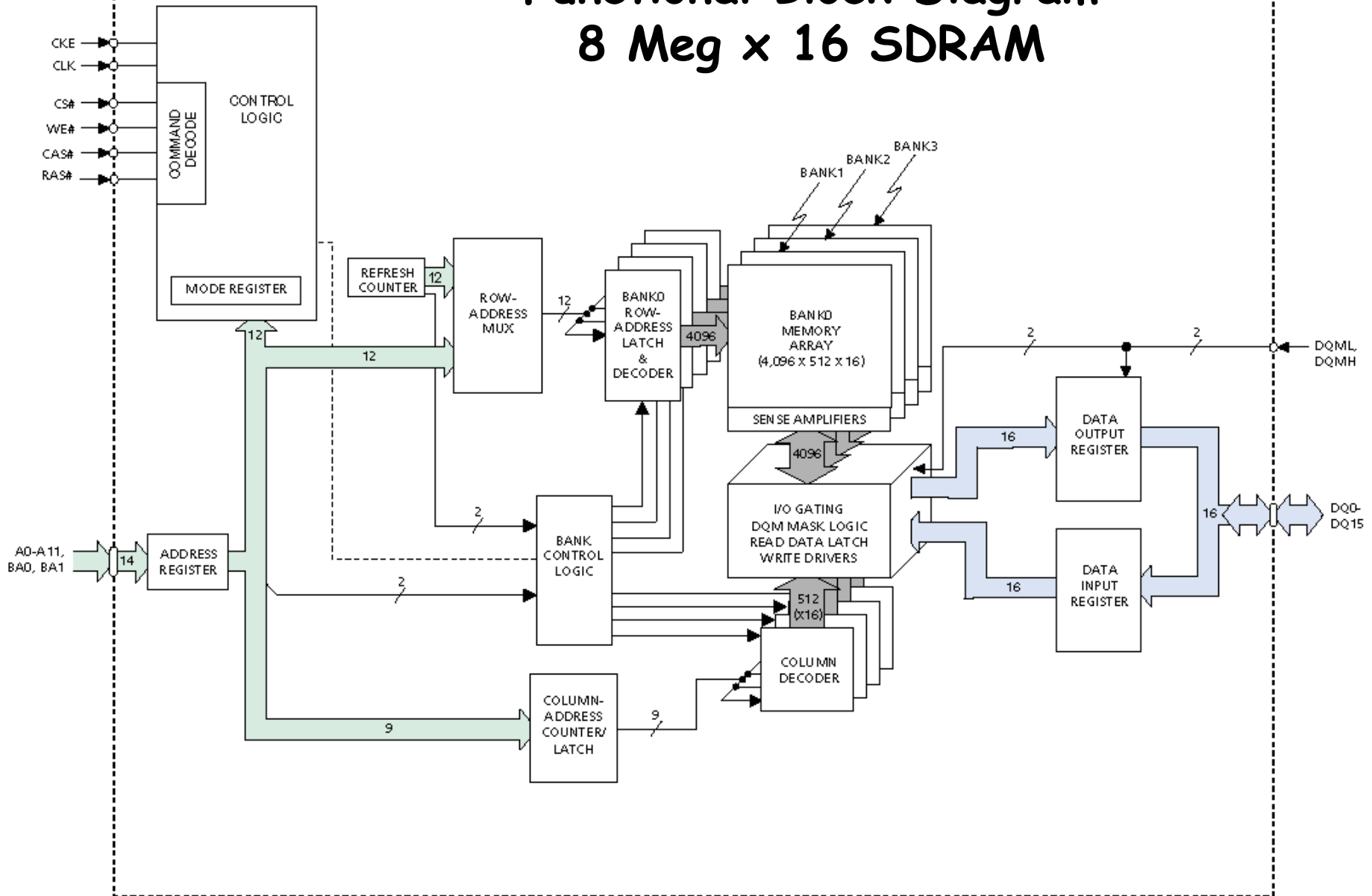

SDRAM Details

- Multiple "banks" of cell arrays are used to reduce access time:
 - Each bank is 4K rows by 512 "columns" by 16 bits (for our part)
- Read and Write operations are split into RAS (row access) followed by CAS (column access)
- These operations are controlled by sending commands
 - Commands are sent using the RAS, CAS, CS, & WE pins.
- Address pins are "time multiplexed"
 - During RAS operation, address lines select the bank and row
 - During CAS operation, address lines select the column.
- "ACTIVE" command "opens" a row for operation
 - transfers the contents of the entire row to a row buffer
- Subsequent "READ" or "WRITE" commands modify the contents of the row buffer.
- For burst reads and writes during "READ" or "WRITE" the starting address of the block is supplied.
 - Burst length is programmable as 1, 2, 4, 8 or a "full page" (entire row) with a burst terminate option.
- Special commands are used for initialization (burst options etc.)
- A burst operation takes $\approx 4 + n$ cycles (for n words)

Mode Register

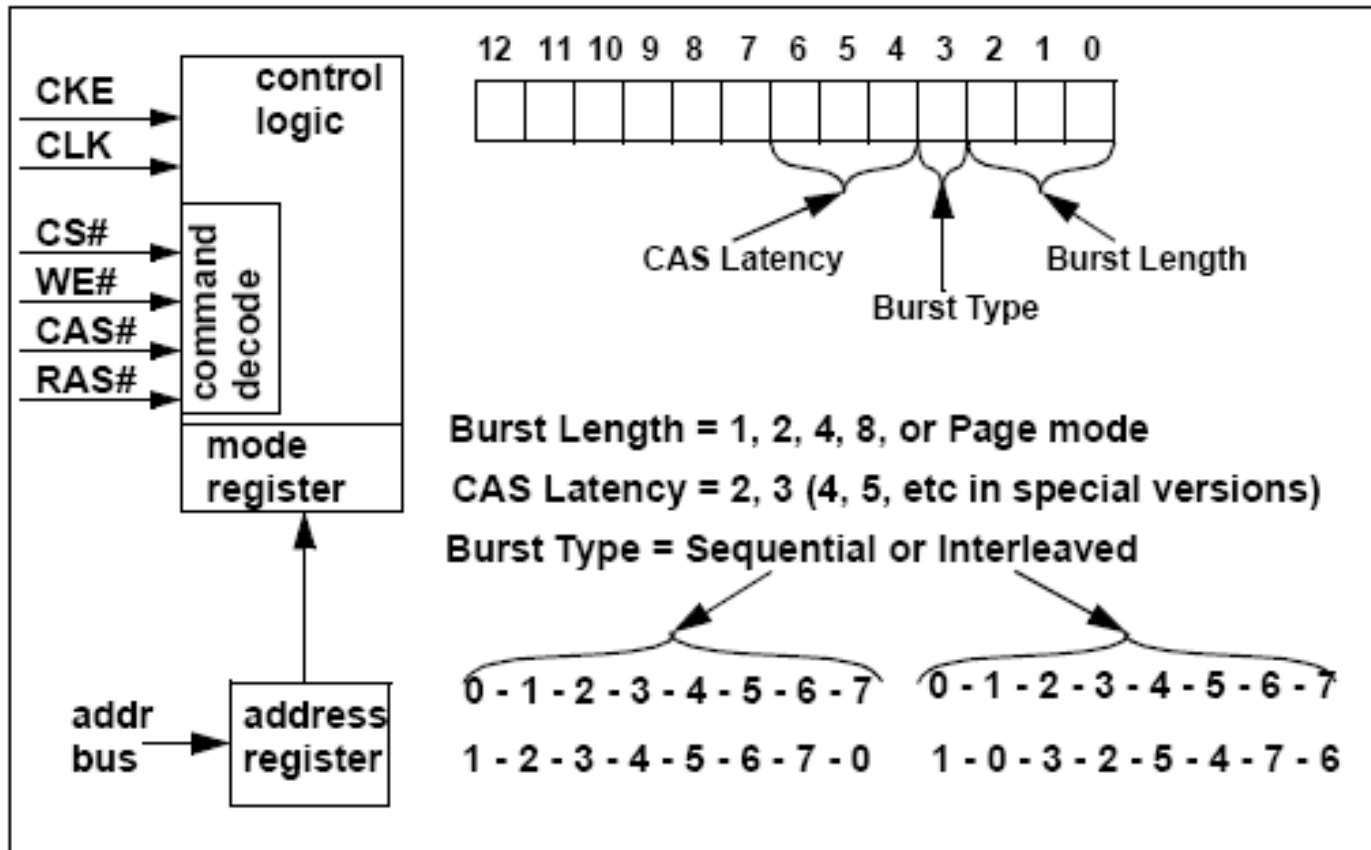

SDRAM Device can be programmed to respond in slightly different manners

Βασικές Χρονικές Παράμετροι SDRAM

- t_{RCD} : ACTIVE to READ or WRITE delay
- CL : CAS Latency
- t_{RAS} : ACTIVE to PRECHARGE time
- t_{RP} : PRECHARGE Period
- t_{WR} : WRITE recovery time
- t_{RC} : ACTIVE to ACTIVE time

READ burst (with auto precharge)

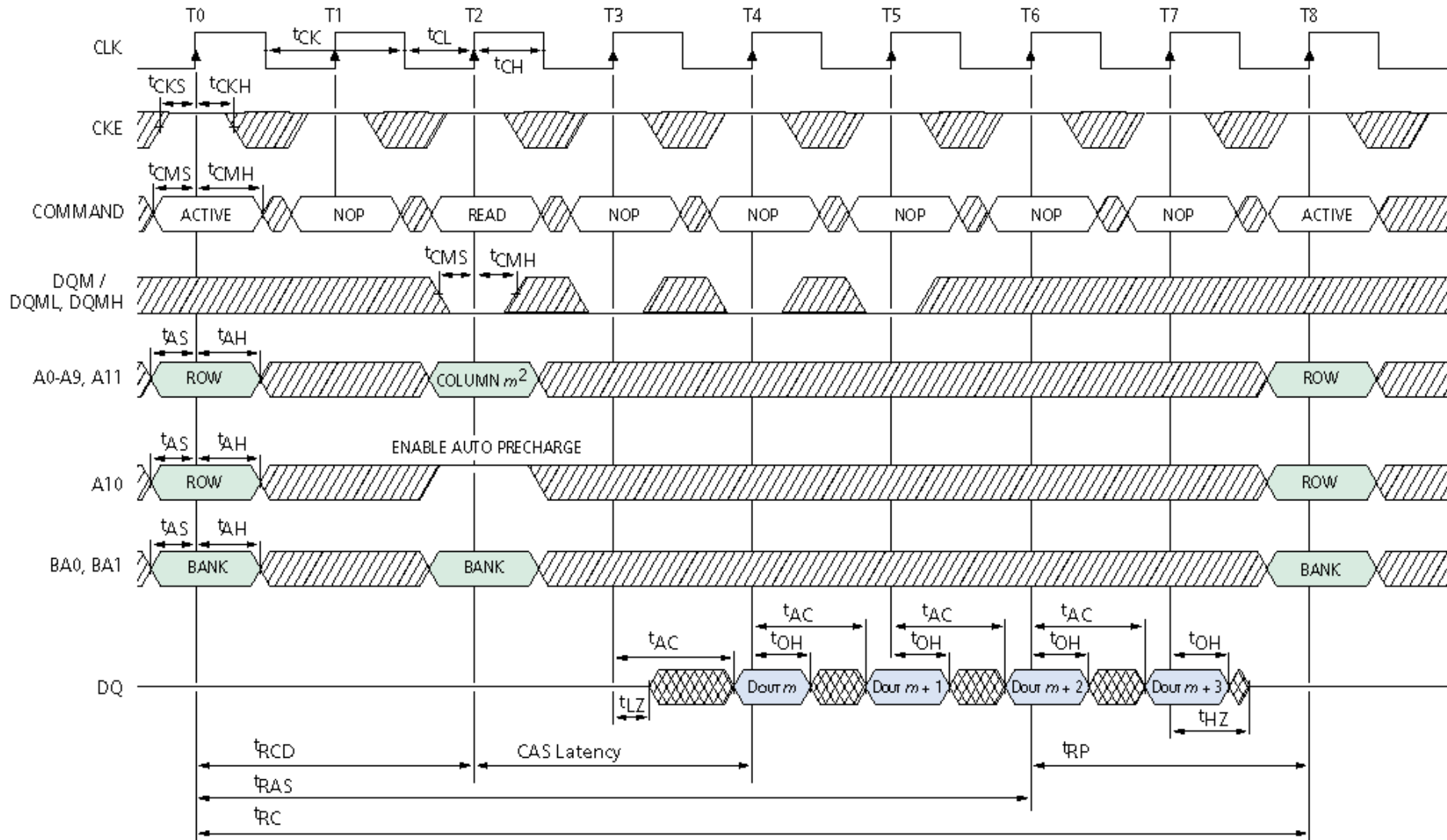

WRITE burst (with auto precharge)

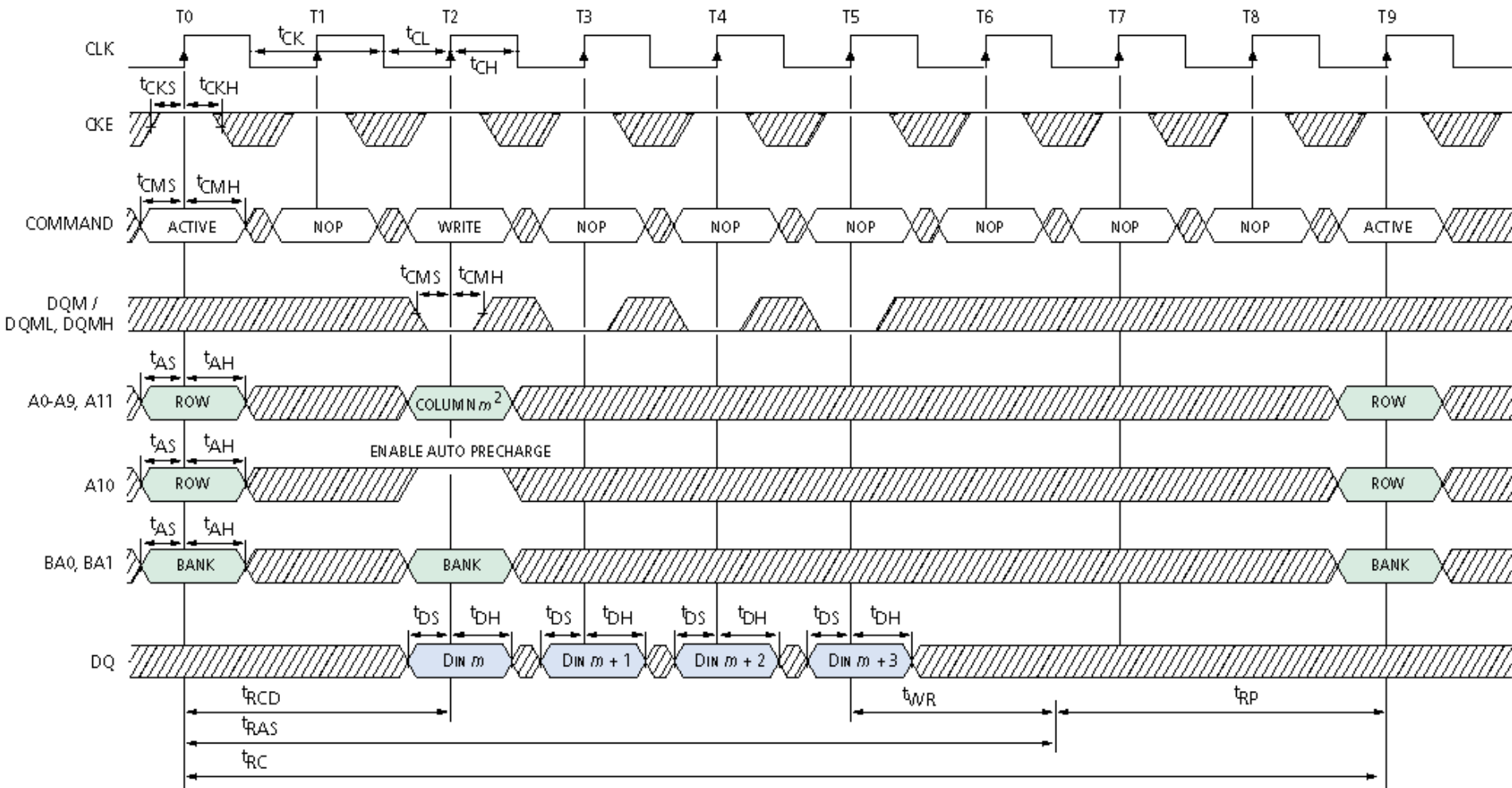

DDR Read Command (with auto precharge)

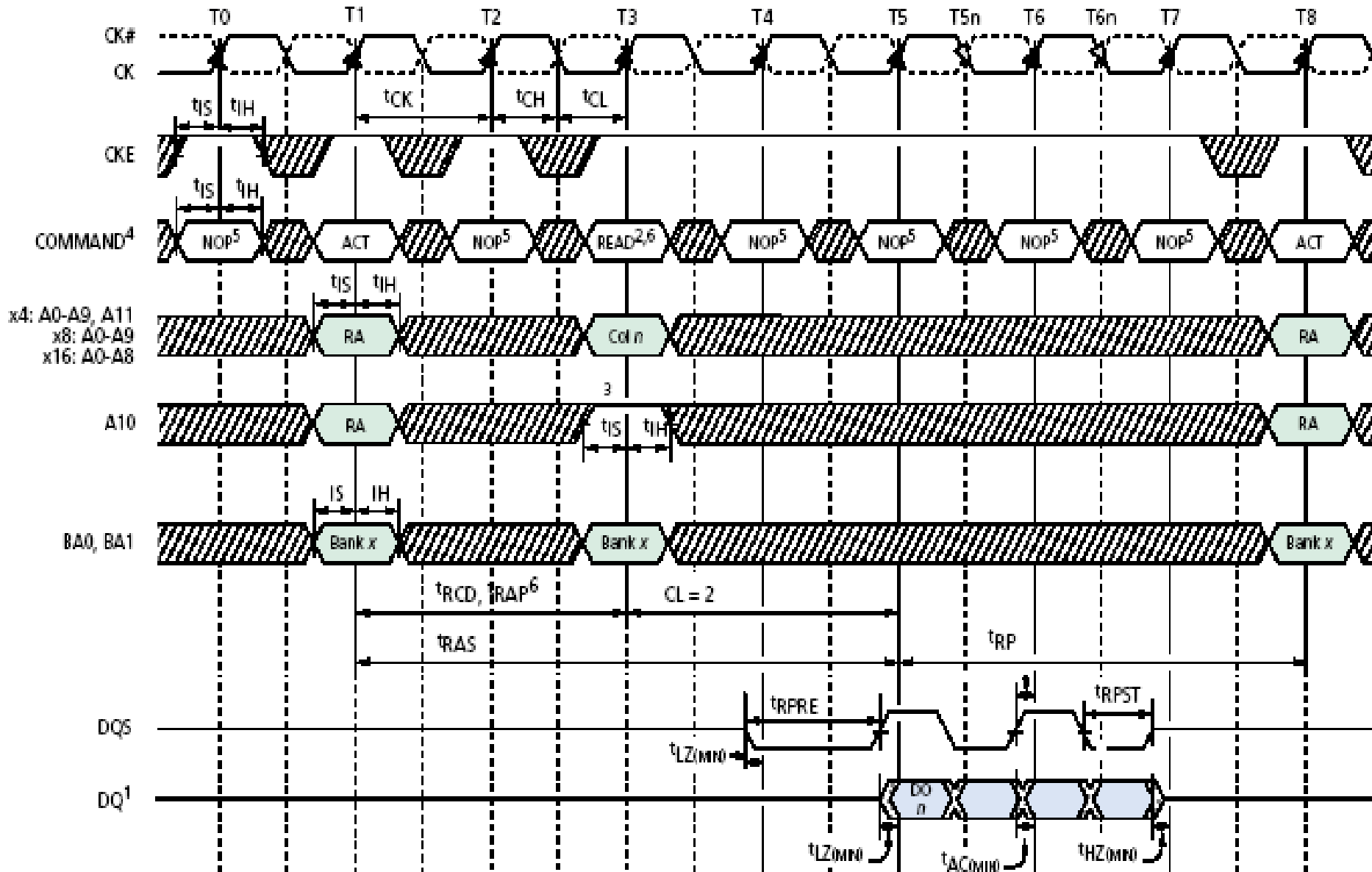

DDR Read Command (without auto precharge)

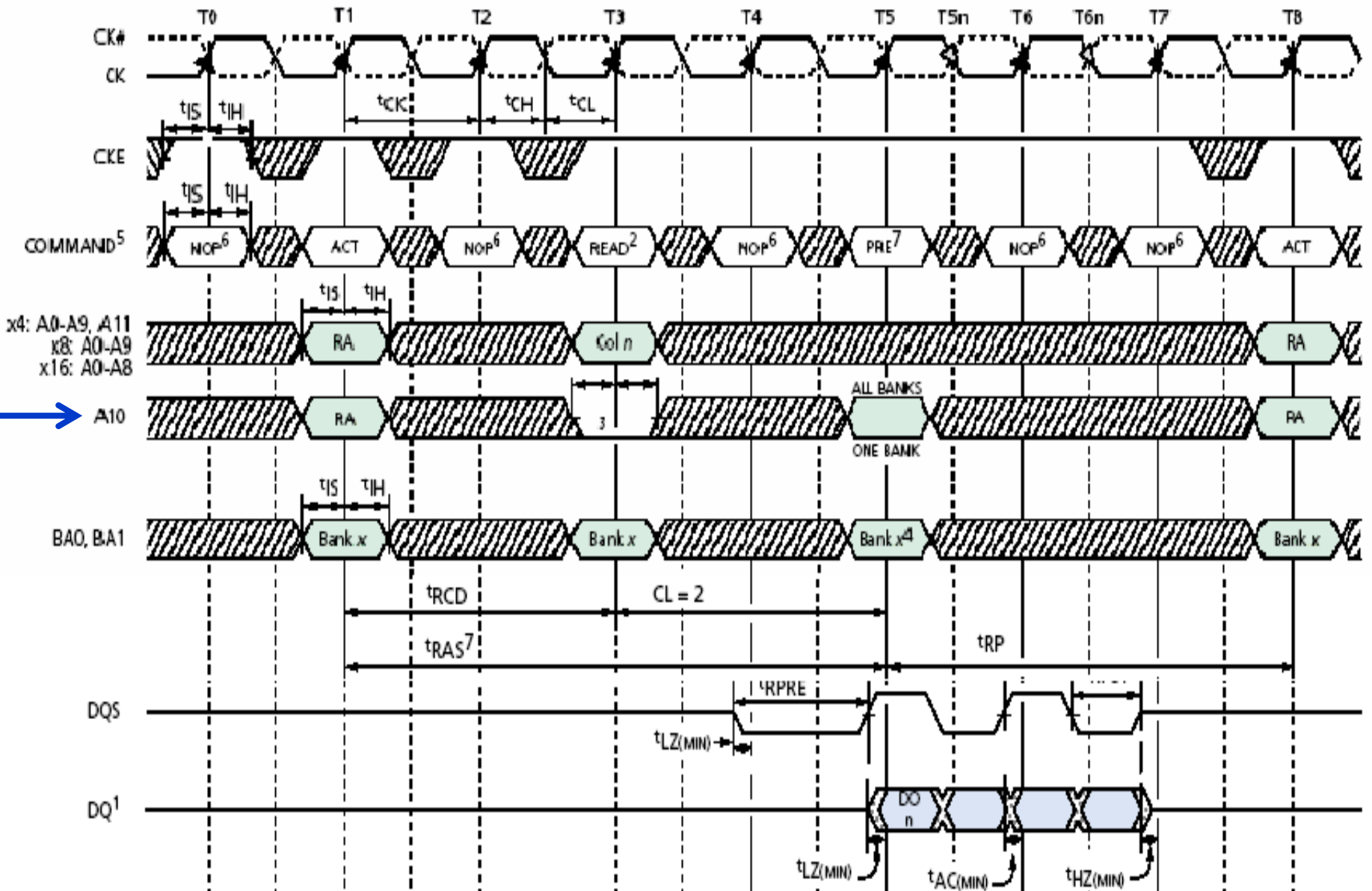

DDR: Consecutive Read Bursts

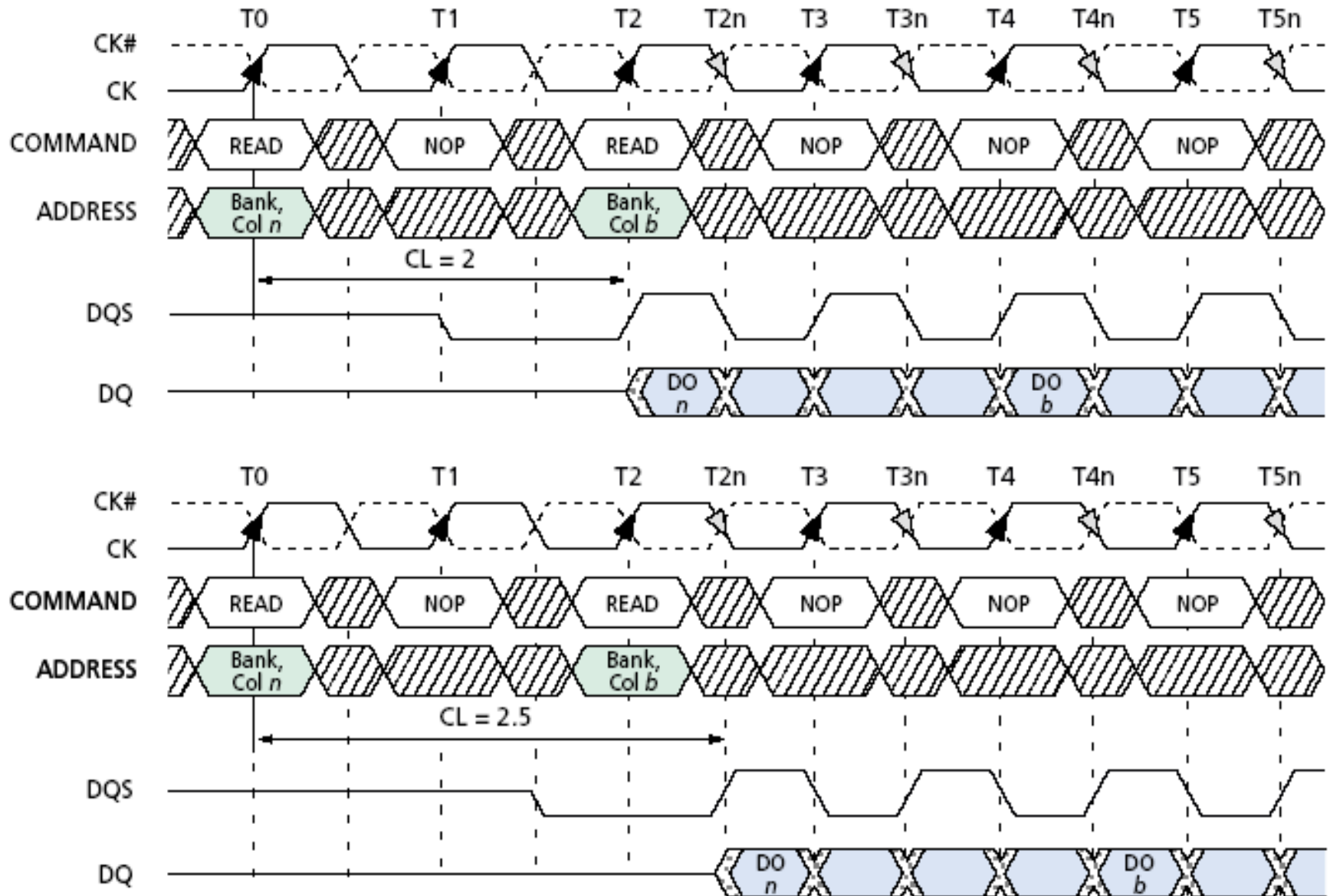

DDR Write Command (without auto precharge)

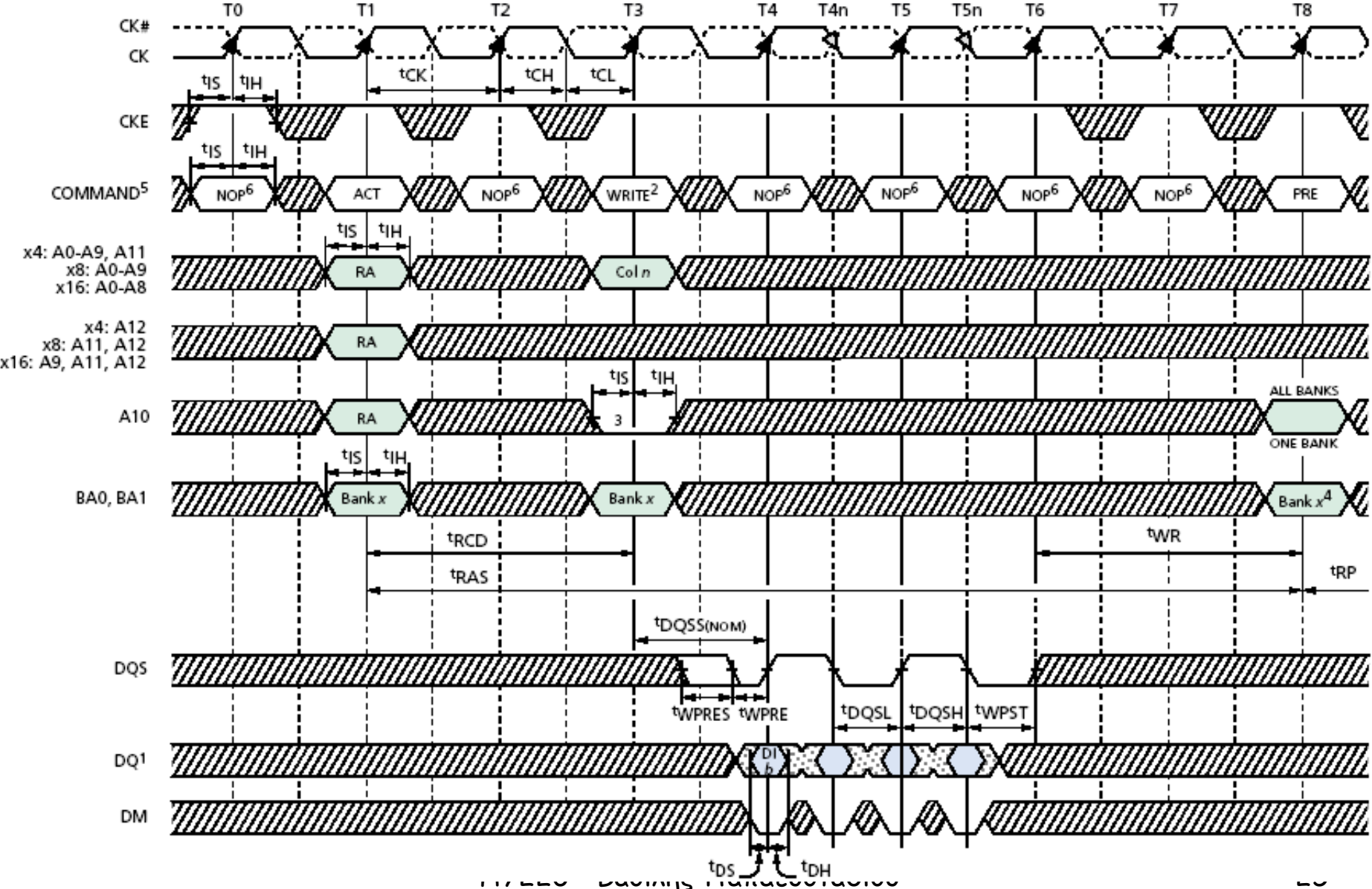

DDR: Read - Burst Stop - Write

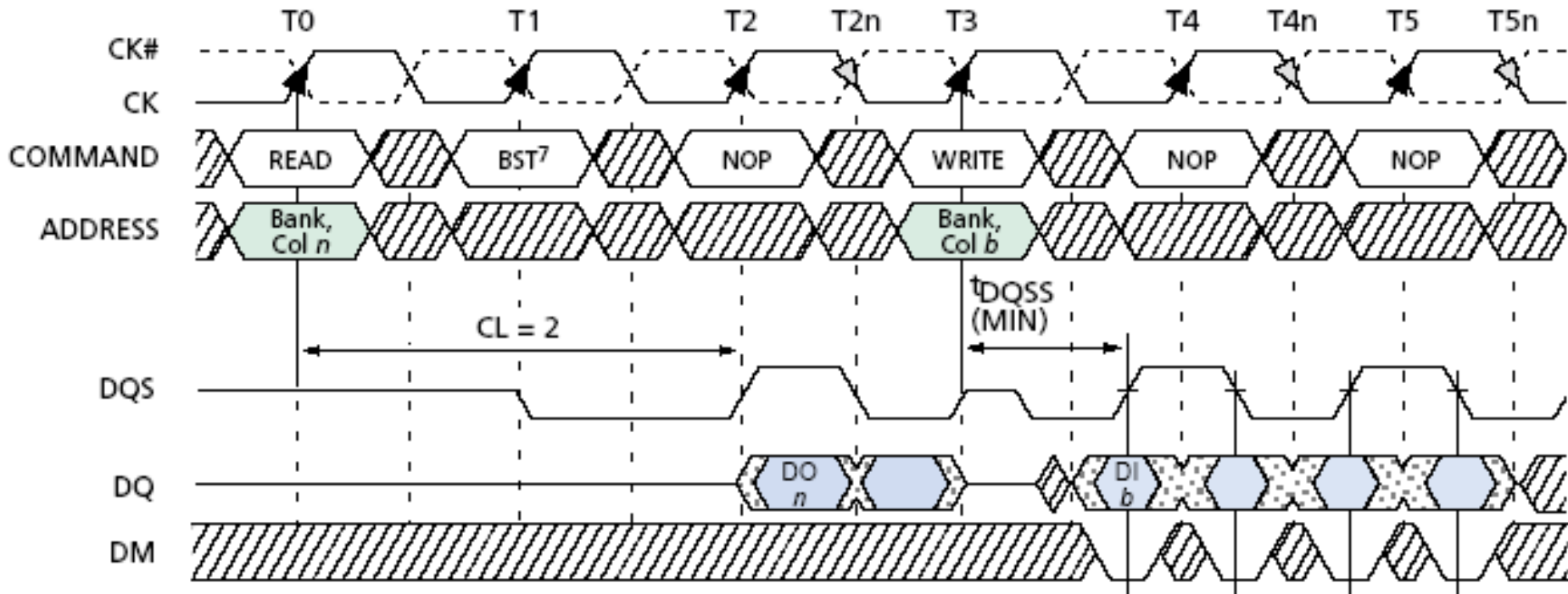

Volatle Memory Comparison

The primary difference between different memory types is the bit cell.

• SRAM Cell

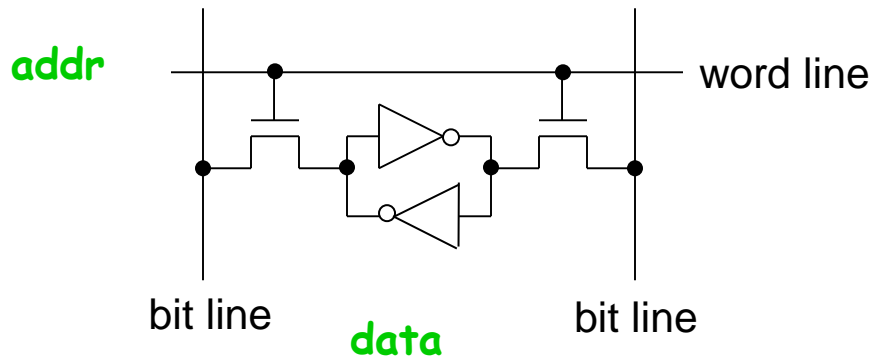

- Larger cell \Rightarrow lower density, higher cost/bit
- No dissipation
- Read non-destructive
- No refresh required
- Simple read \Rightarrow faster access
- Standard IC process \Rightarrow natural for integration with logic

• DRAM Cell

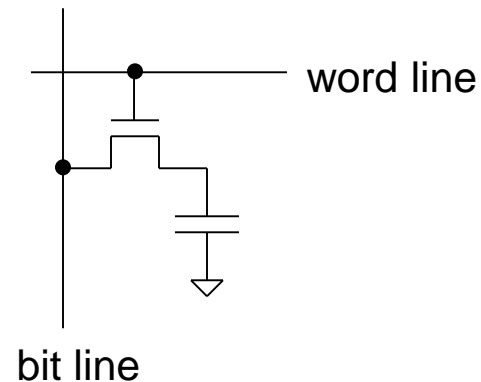

- Smaller cell \Rightarrow higher density, lower cost/bit
- Needs periodic refresh, and refresh after read
- Complex read \Rightarrow longer access time
- Special IC process \Rightarrow difficult to integrate with logic circuits
- Density impacts addressing